

**Comal Concrete Products, Inc.**  
**4222 FM 482 NEW BRAUNFELS, TX 78132**  
 EMAIL: [comalconcrete@comalconcrete.com](mailto:comalconcrete@comalconcrete.com)  
 830-608-1699 SA Metro: 830-606-4732 Fax: 830-608-1396

**5000 GALLON  
 GREASE INTERCEPTOR**

NOTE: DRAWING NOT TO SCALE

8" TRAFFIC LID (STD)  
 W/ 2 HOLES 24" DIA.

PLAN VIEW TOP

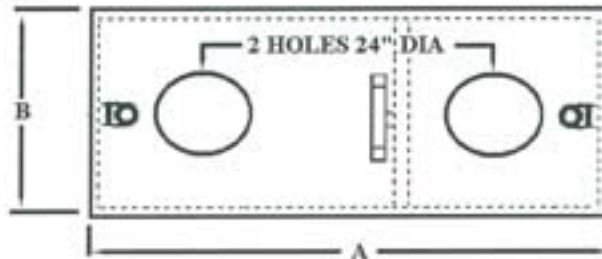

GALLON	DIM. A	DIM. B	DIM. C
5000	216	108	88

SECTION:ELEVATION

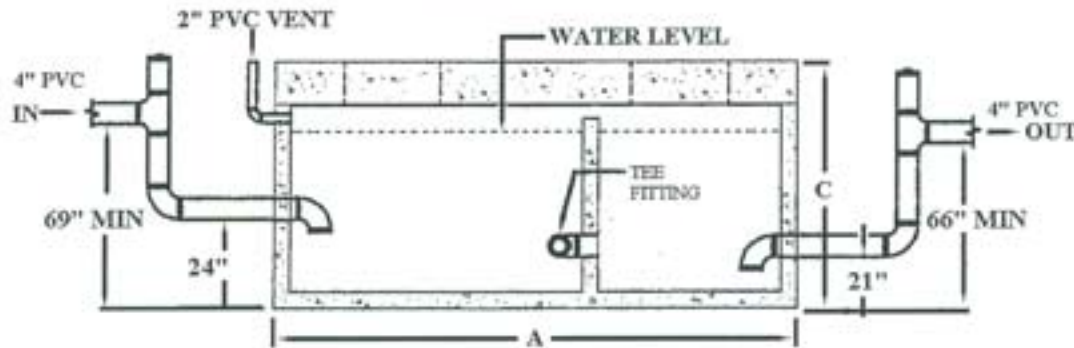

8" TRAFFIC LID (STD)

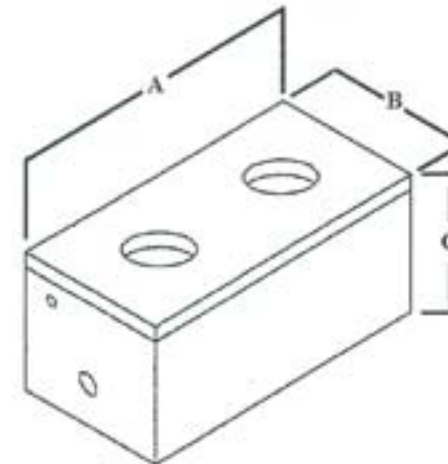

**SAN ANTONIO**

LOW PROFILE INTERCEPTOR

**CONCRETE:**

4500 PSI CONFORMING TO ASTM C 150

**STEEL REINFORCEMENT:**

GRADE 60 CONFORMING TO ASTM A 615

**SPECIFICATION:**

AASHTO H20-44 8" TRAFFIC LID (STD)

6" TO 8" DEPTH OF PEA GRAVEL BED

RECOMMENDED BY MANUFACTURE

