

**Comal Concrete Products, Inc.**  
 4222 FM 482 NEW BRAUNFELS, TX 78132  
 EMAIL: [comalconcrete@comalconcrete.com](mailto:comalconcrete@comalconcrete.com)  
 830-608-1699 SA Metro: 830-606-4732 Fax: 830-608-1396

**500 GALLON TO  
 2000 GALLON  
 SEPTIC TANKS**

NON TRAFFIC

PLAN VIEW TOP  
 2 - 24" ACCESS PORTS

NOTE: DRAWING NOT TO SCALE

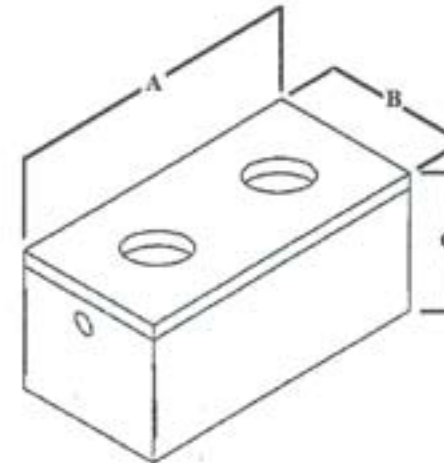
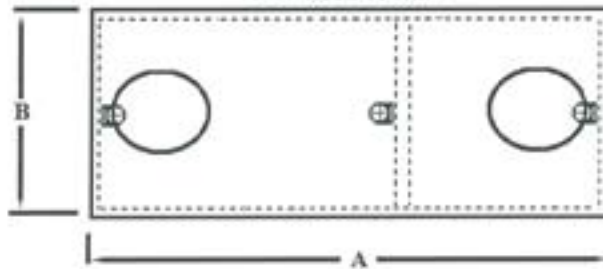

SECTION: ELEVATION

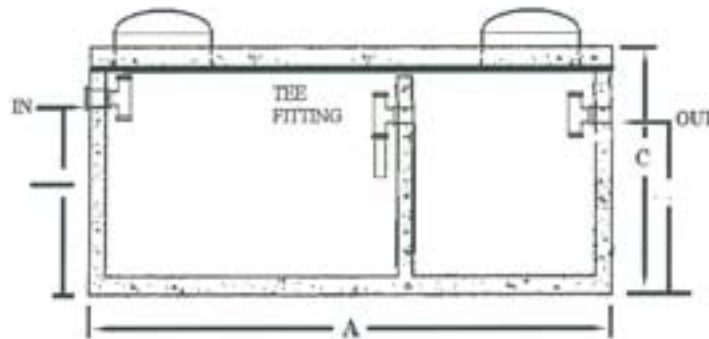

**SEPTIC TANK**

DESIGN CONFORMS TO: ASTM C 1227

**CONCRETE:**

4500 PSI CONFORMING TO ASTM C 150

**STEEL REINFORCEMENT:**

GRADE 60 CONFORMING TO ASTM A 615

**BEDDING SPECIFICATION:**

6" TO 8" DEPTH OF PEA GRAVEL BED

RECOMMENDED BY MANUFACTURER

GALLON	CAP	DIM. A	DIM. B	DIM. C	FLOW -IN	FLOW -OUT	COMPARTMENTS
500		68	68	54	45	42	SINGLE
750		100	65	52	43	40	DOUBLE
1000		103	79	52	43	40	DOUBLE
1250		129	80	52	43	40	DOUBLE
1500		151	83	50	40	37	DOUBLE
2000		176	74	60	50	47	DOUBLE